

# MIL-DTL-26482 SERIES I CONNECTOR



**MIL-DTL-26482 Ser.I Connectors  
Uses a quick disconnect bayonet  
Coupling and 5 Keyways**



# MIL-DTL-26482 Series I

---

<b>Contents</b>	<b>2</b>
<b>Features</b>	<b>2</b>
<b>Technical Data</b>	<b>3</b>
<b>Mounting Dimensions</b>	<b>5</b>
<b>Shell style</b>	<b>6</b>
<b>How to order</b>	<b>7</b>
<b>Contact Arrangements</b>	<b>8</b>
<b>Connector Dimensions</b>	<b>15</b>
<b>Termination Assembly</b>	<b>15</b>
<b>Accessories</b>	<b>22</b>
<b>Cross Reference Lists</b>	<b>23</b>

# MIL-DTL-26482 Series I

---

## Contents

### Introduction

The KD MIL-DTL-26482 SERIES I Connectors offers high density contact arrangements in a miniature circular metal shell.

This series conforms to MIL-DTL-26482 and are intermateable, intermountable and interchangeable with all MIL-DTL-26482 Connectors.

This series uses a quick disconnect bayonet coupling and 5 keyways for rapid positive mating and unmating of the connector.

### Applications

Military and industrial environments requiring a miniature, high density, environmental connector.

- Power generators
- Engines
- Sensors
- Motion Control
- Off-road vehicles
- Earth moving equipment
- Ships
- Mobile equipment
- Industrial machinery
- Telecommunications

## Features

### Rugged Shell

Aluminum alloy shell and hardware create a rugged connector with minimal weight.

These connectors have been used extensively in commercial, military and aerospace environments. Standard shells accept all MIL-DTL-26482 accessories.

### Environmentally Sealed

Complete moisture sealing is achieved by combining four seals: shell, peripheral, interfacial and wire. Wire Seal is accomplished by multiple ripple design, exceeding the wire sealing requirements of MIL-DTL-26482.

### Resistant to Military Environments

These connectors will operate in temperatures  $-55^{\circ}\text{C}$  to  $+125^{\circ}\text{C}$  ( $-67^{\circ}\text{F}$  to  $+257^{\circ}\text{F}$ ) under the harshest possible conditions.

### Wide Range of Wire Gauges and Current Carrying Capability

Up to 22 amps with wire gauges from size 24 up to size 16 AWG wire.

### Resilient Insulator & Grommet

A resilient synthetic rubber insulator and integrated rear wire sealing grommet guarantees a liquid tight assembly.

Solder contacts are permanently bonded into the insulator.

# MIL-DTL-26482 Series I

## Technical Data

### Electrical Data

#### Contact rating at +20°C

Contact size AWG	Current max. A
20	7.5
16	22
12	35

### Insulation resistance

The insulation resistance to be tested per EIA364.21 and MIL-DTL-26482 3.6.6 test condition B; DC500V/5000MΩmin

### Operating & Test voltage

The dielectric withstanding voltage to be tested per EIA364.20 and MIL-DTL-26482 3.6.8

Service rating	Operating voltage	
	DC	AC(rms)
I	850V	600V
II	1,275V	1,000V

Service rating	Test voltage AC(rms)		
	Sea level	50,000 ft	70,000 ft
I	1,500V	500V	375V
II	2,300V	750V	500V

### Contact resistance

Voltage drops to be tested per EIA364.06 and MIL-DTL-26482 3.6.4

Contact size AWG	Test current A	millivolt max. mV
20	7.5	55
16	13	50
12	23	50

### Mechanical Features

#### Ambient temperature

-55°C/+125°C

#### Water pressure

48hours in 6feet per MIL-DTL-26482 3.6.14

#### Humidity

20-day 50 to 90% humidity testing per MIL-DTL-26482 3.6.25

#### Mating cycles

500cycle.

#### Salt spray

Unmated connectors and protective covers meet 48hour exposure per EIA364.26 and MIL-DTL-26482 3.6.19

#### Vibration

10 $\mu$ s max at 10 to 2,000Hz(15g) discontinuity per EIA364.28 and MIL-DTL-26482 3.6.21

#### Shock

50g's/11ms duration, three major axes 10 $\mu$ s max discontinuity per EIA364.27 and MIL-DTL-26482 3.6.23

### Contact retention

The contact retention to be tested per EIA364.29 and MIL-DTL-26482 3.6.32

Contact size AWG	Test force N (LB)
20	66.7 (15)
16	111.2 (25)
12	111.2 (25)



# MIL-DTL-26482 Series I

## Wire sealing range

Contact size	Wire size AWG	Insulation O.D limits	
		min. mm	max. mm
20	24, 22 & 20	1.19	2.11
16	20, 18 & 16	1.68	2.77
12	14, 12	2.46	3.61

## Materials

### Shell

Material	Aluminum alloy
Finish	Olive drab chromate coating over cadmium plating
alternative finish	Black over zinc plating (RoHS)

## Insulation strip lengths

Contact size	Wire size AWG	Strip length mm
20	20 – 24	9.5
16	16 – 20	6.4

## Insulator and grommets

Material	Synthetic rubber
----------	------------------

### Contacts

Material	Copper alloy
Finish	Gold plate

## Cross Sections

The diagram shows a typical cross-section of a mated pair of connectors.

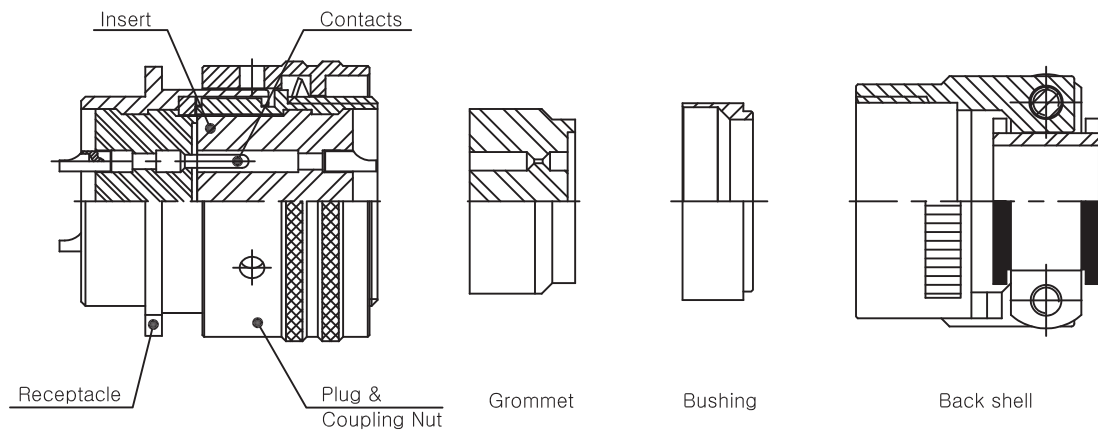

# MIL-DTL-26482 Series I

## Mounting Dimensions

### Mounting holes

Front Mount

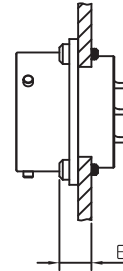
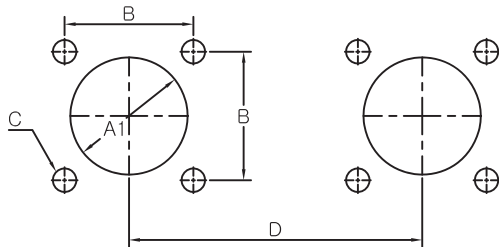

Rear Mount

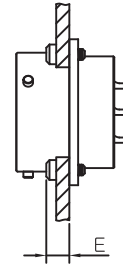
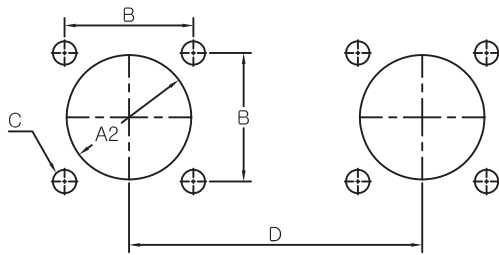

Jam Nut Mount

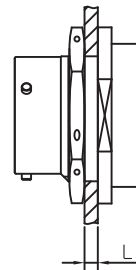
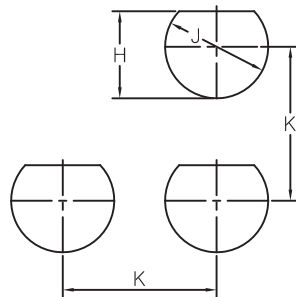

Shell Size	∅A1 -0.25	∅A2 -0.25	B ±0.15	C +0.10	D min	E max	H -0.2	J +0.2	K min	L	
										min	max
8	11.63	14.73	15.09	3.10	21.4	2.21	13.7	14.5	24.6	1.57	3.18
10	14.81	17.78	18.26	3.10	24.6	2.21	16.9	17.7	27.8	1.57	3.18
12	17.98	21.82	20.62	3.10	27.0	2.21	21.0	22.5	32.6	1.57	3.18
14	21.16	24.97	23.01	3.10	29.4	2.21	24.2	25.7	35.7	1.57	3.18
16	24.33	28.14	24.61	3.10	31.7	2.21	27.3	28.8	38.9	1.57	3.18
18	27.51	31.32	26.97	3.10	34.1	2.21	30.5	32.0	42.1	1.57	3.18
20	30.68	34.52	29.36	3.10	37.3	5.38	33.7	35.2	46.8	1.57	6.35
22	33.86	37.92	31.75	3.10	40.5	5.38	36.9	38.4	50.0	1.57	6.35
24	37.03	41.00	34.93	3.80	43.6	5.38	40.0	41.5	53.2	1.57	6.35

# MIL-DTL-26482 Series I

## Shell style

### Plug or Receptacle

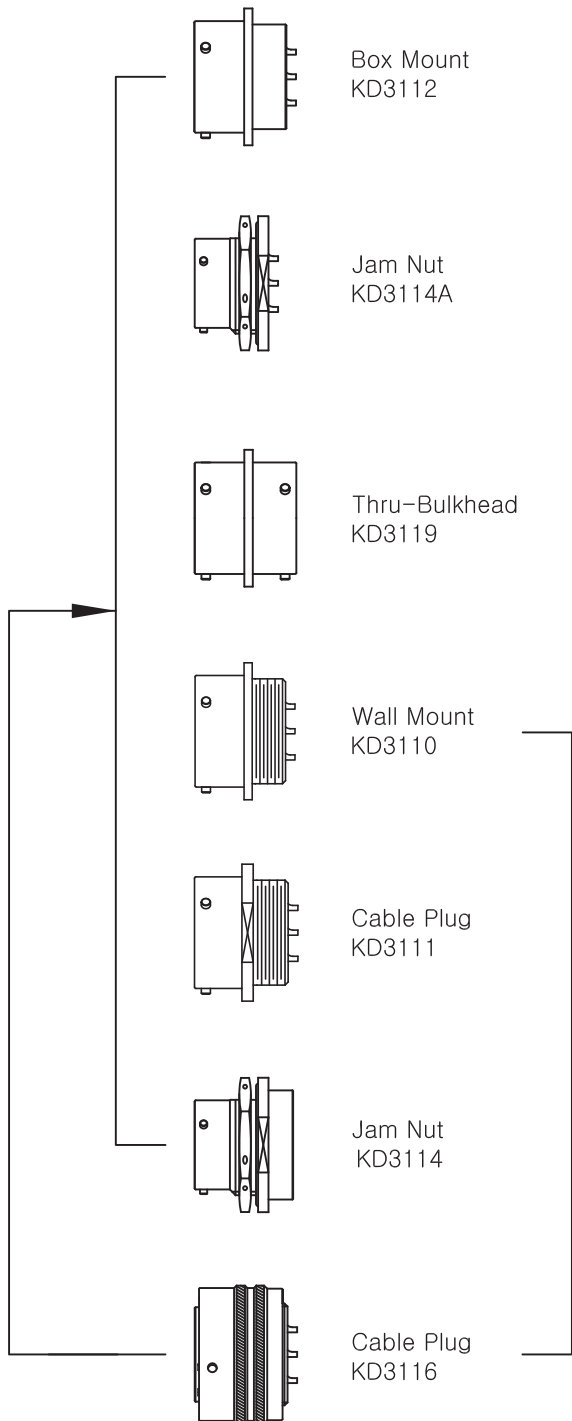

### Choose Endbell

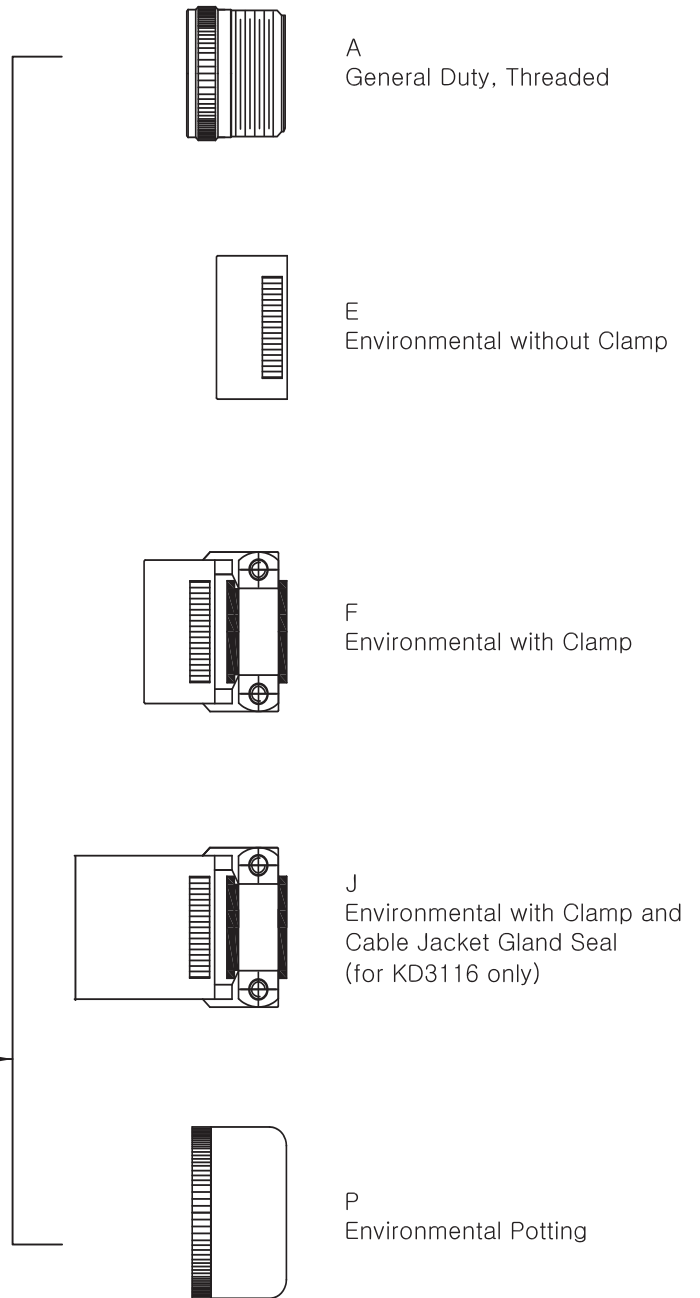

# MIL-DTL-26482 Series I

## How to order

### KD Order Reference

KD 3112E 12-10PW \*\*

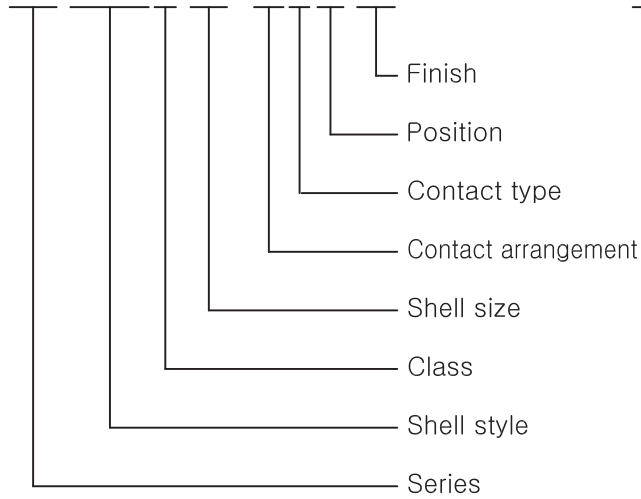

### MS Order Reference

MS 3112E 12-10PW \*\*

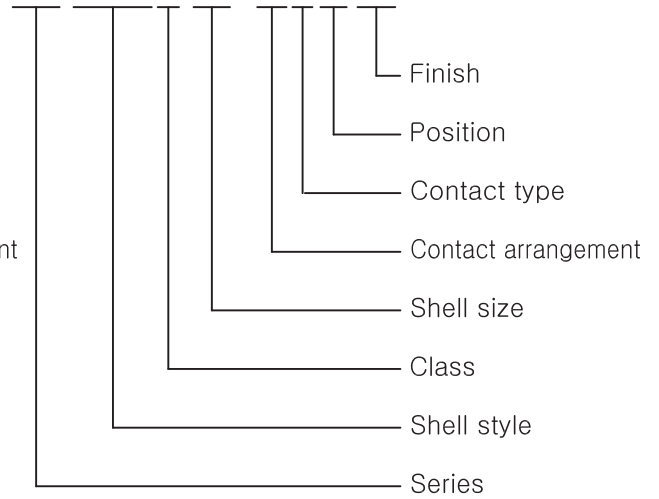

### Series

- KD Kd circular connectors with bayonet coupling
- MS Military Standard

### Shell style

- 3110 Wall mounting receptacle
- 3111 Cable connecting plug
- 3112 Box mounting receptacle
- 3114 Jam Nut mounting receptacle
- 3115 Dummy receptacle
- 3116 Straight plug
- 3119 Thru-bulkhead receptacle

### Class

- A General duty, threaded back shell
- E Grommet seal except on KD3112
- F Grommet seal with strain relief
- J Cable seal with clamp (KD3116 only)
- P Potting seal

### Shell size

- 8, 10, 12, 14, 16, 18, 20, 22, 24

### Contact arrangement

See page 8~13

### Contact type

- P – Pin contact
- S – Socket contact
- C – Feedthrough contact (only for KD3119)

### Position

See page 8~9

### Finish

- No Code Olive drab cadmium plate finish as standard
- F Electroless Nickel
- Z3 Black over Zinc plating (RoHS)
- A4 Black over Anodize
- N Nickel plating

# MIL-DTL-26482 Series I

## Contact Arrangements Alternate Insert Positions

※ View shows pin front side or socket rear side

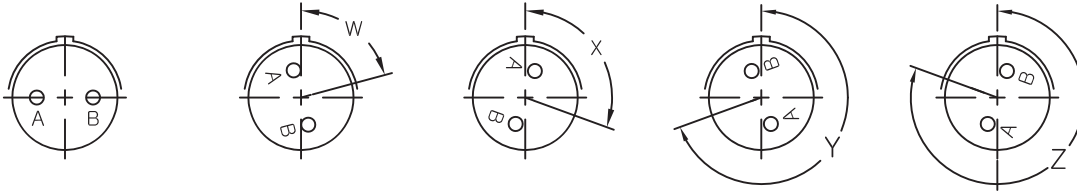

Shell Size	Insert Number	Contacts					Alternate pos.				Service rating
		Tot	20	16	12	8	W	X	Y	Z	
8	8-2	2	2				58	122			I
	8-3	3	3				60	210			I
	8-4	4	4				45				I
	8-33	3	3				90				I
	8-98	3	3				60				I
10	10-5	5	5				45	151	180	270	I
	10-6	6	6				90				I
	10-7	7	7								I
	10-98	6	6				90	180	240	270	I
12	12-3	3		3					180		II
	12-4	4		4			38				I
	12-8	8	8				90	112	203	292	I
	12-10	10	10				60	155	270	295	I
	12-12	12	12								I
	12-14	14	14								I
14	14-4	4			4		45				I
	14-5	5		5			40	92	184	273	II
	14-9	9	5		4		15	90	180	240	I
	14-12	12	8	4			43	90			I
	14-15	15	14	1			17	110	155	234	I
	14-18	18	18				15	90	180	270	I
	14-19	19	19				30	165	315		I
16	16-8	8		8			54	152	180	331	II
	16-14	14	8		6		25	78	180	240	I
	16-23	23	22	1			158	270			I
	16-26	26	26				60		275	338	I
	16-99	23	21	2			66	156	223	340	I

# MIL-DTL-26482 Series I

## Contact Arrangements Alternate Insert Positions

※ View shows pin front side or socket rear side

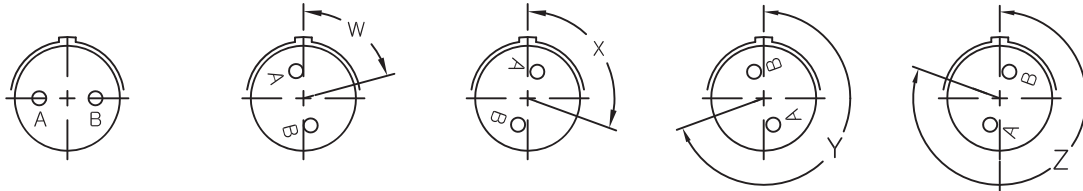

Shell Size	Insert Number	Contacts					Alternate pos.				Service rating
		Tot	20	16	12	8	W	X	Y	Z	
18	18-5	5			5		55	97	263	315	I
	18-8	8			8		180				I
	18-11	11		11			62	119	241	340	II
	18-28	28	26	2			49	158	207	329	I
	18-30	30	29	1			180	193	285	350	I
	18-32	32	32				85	138	222	265	I
	18-85	13	5		8		45	90	180	240	I
20	20-16	16		16			238	318	333	347	II
	20-24	24	24				70	145	215	290	I
	20-27	27	27				72	144	216	288	I
	20-39	39	37	2			63	144	252	333	I
	20-41	41	41				45	126	225		I
	20-90	15	3		12		18	60	240	270	I
22	22-12	12			12						I
	22-19	19			19		15	90	225	308	I
	22-21	21		21			16	135	175	349	II
	22-32	32	32				72	145	215	288	I
	22-34	34	34				62	142	218	298	I
	22-41	41	27	14			39	135	264		I
	22-55	55	55				30	142	226	314	I
22-95	32	26		6		26	180	266		I	
24	24-19	19			19		30	165	315		I
	24-27	27	11		16		45	110	140	225	I
	24-31	31		31			90	225	255		I
	24-61	61	61				90	180	270	324	I

# MIL-DTL-26482 Series I

## Contact Arrangements

### Shell Size 8



Insert number	8-2	8-3	8-4	8-33
No. of contacts	2	3	4	3
Contact size	20	20	20	20
Service rating	I	I	I	I

### Shell Size 10

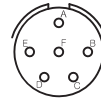
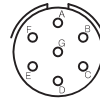
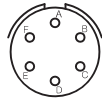
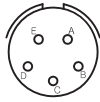

Insert number	10-5	10-6	10-7	10-98
No. of contacts	5	6	7	6
Contact size	20	20	20	20
Service rating	I	I	I	I

### Shell Size 12

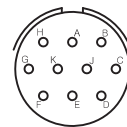
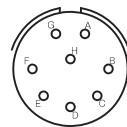
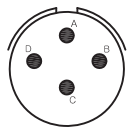
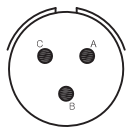

Insert number	12-3	12-4	12-8	12-10
No. of contacts	3	4	8	10
Contact size	16	16	20	20
Service rating	II	I	I	I

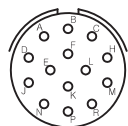
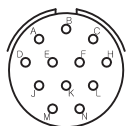

Insert number	12-12	12-14
No. of contacts	12	14
Contact size	20	20
Service rating	I	I

# MIL-DTL-26482 Series I

## Shell Size 14

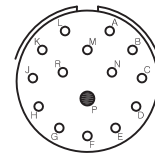
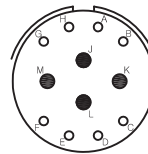
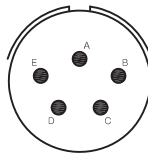
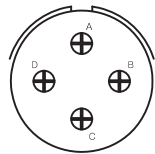

Insert number	14-4	14-5	14-12	14-15
No. of contacts	4	5	12	15
Contact size	12	16	8-20, 4-16	14-20, 1-16
Service rating	I	II	I	I

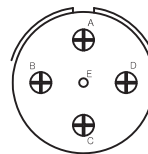
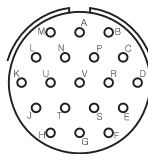
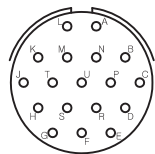

Insert number	14-18	14-19	14-22
No. of contacts	18	19	5
Contact size	20	20	1-20, 4-12
Service rating	I	I	I

## Shell Size 16

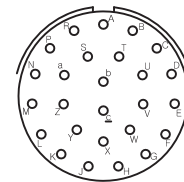
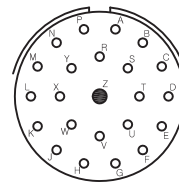
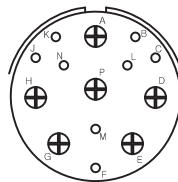
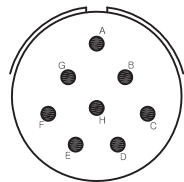

Insert number	16-8	16-14	16-23	16-26
No. of contacts	8	14	23	23
Contact size	16	8-20, 6-12	22-20, 1-16	26
Service rating	II	II	I	I



# MIL-DTL-26482 Series I

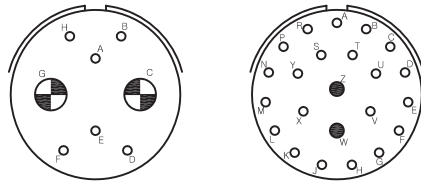

Insert number	16-95	16-99
No. of contacts	8	23
Contact size	2-8, 6-20	21-20, 2-16
Service rating	II	I

## Shell Size 18

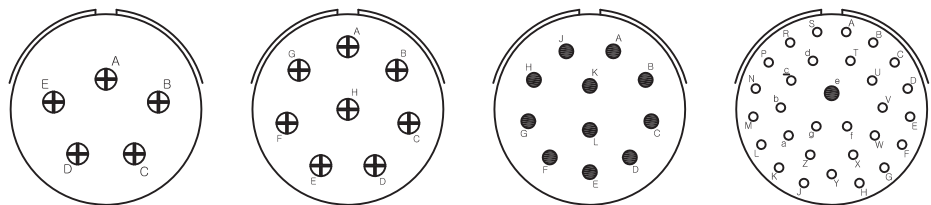

Insert number	18-5	18-8	18-11	18-30
No. of contacts	5	8	11	30
Contact size	12	12	16	29-20, 1-16
Service rating	I	I	II	I

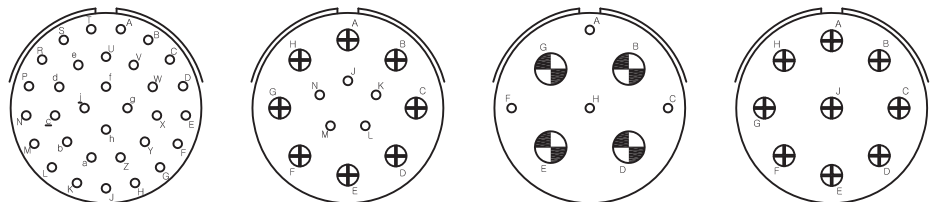

Insert number	18-32	18-85	18-88	18-96
No. of contacts	32	13	8	9
Contact size	20	5-20, 8-12	4-20, 4-8	12
Service rating	I	I	I	I

# MIL-DTL-26482 Series I

## Shell Size 20

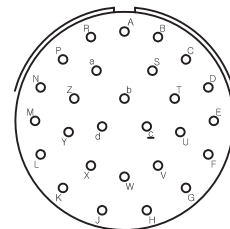
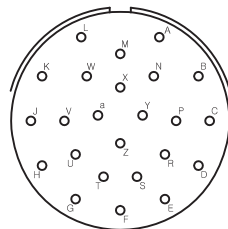
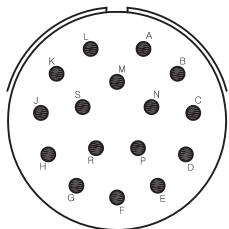

Insert number	20-16	20-24	20-27
No. of contacts	16	20	27
Contact size	16	24	20
Service rating	II	I	I

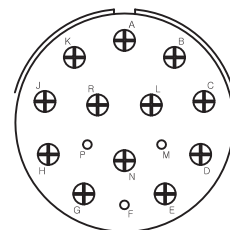
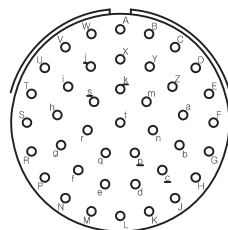
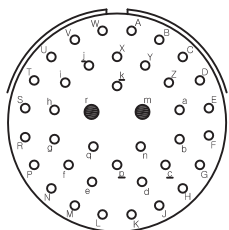

Insert number	20-39	20-41	20-90
No. of contacts	39	41	15
Contact size	37-20, 2-16	20	3-20, 12-12
Service rating	I	I	I

## Shell Size 22

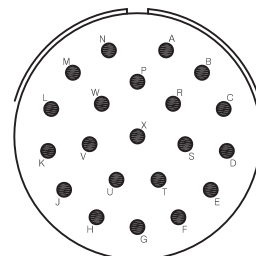
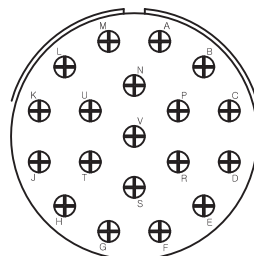
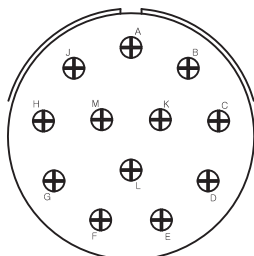

Insert number	22-12	22-19	22-21
No. of contacts	12	19	21
Contact size	12	12	16
Service rating	I	I	II

# MIL-DTL-26482 Series I

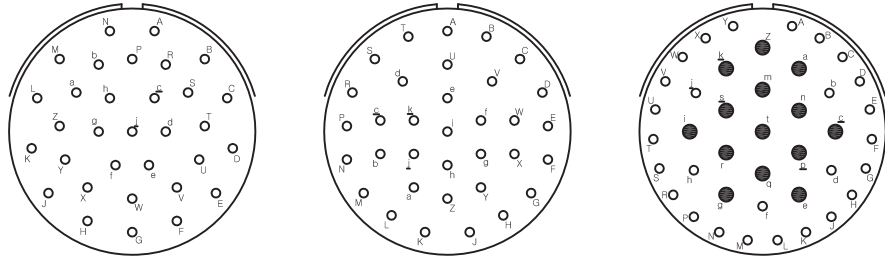

Insert number	22-32	22-34	22-41
No. of contacts	32	34	41
Contact size	20	20	27-20, 14-16
Service rating	I	I	I

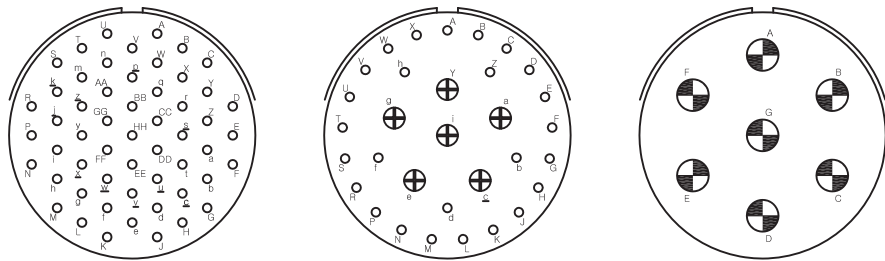

Insert number	22-55	22-95	22-96
No. of contacts	55	32	7
Contact size	20	26-20, 6-12	20
Service rating	I	I	I

## Shell Size 24

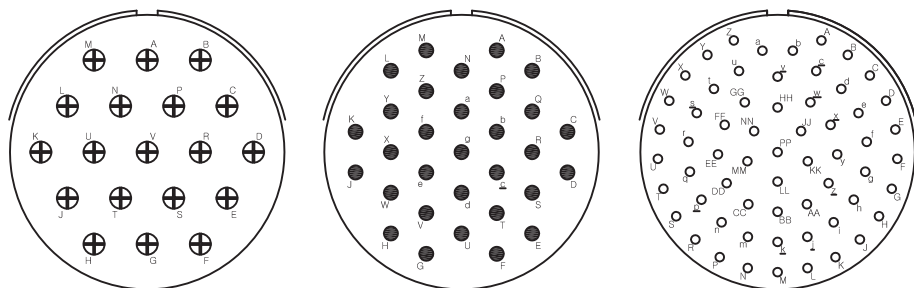

Insert number	24-19	24-31	24-61
No. of contacts	19	31	61
Contact size	12	16	20
Service rating	I	I	I

# MIL-DTL-26482 Series I

## Connector Dimensions

KD3110 Class A, E, F, J & P  
 MS3110 Class A, E, F, J & P  
 Wall Mounting Receptacle

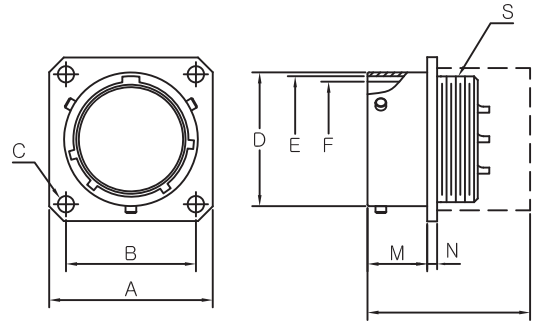

Termination Assembly

Shell size	□A max	□B ±0.13	∅C ±0.13	∅D +0.03 -0.13	∅E +0.13 -0.15	∅F +0.13 -0.03	M +0.79	N ±0.41	S THD-2A
8	21.03	15.09	3.05	12.01	10.46	9.19	10.95	1.57	7/16-28UNEF
10	24.23	18.26	3.05	14.99	13.72	12.45	10.95	1.57	9/16-24UNEF
12	26.59	20.62	3.05	19.05	17.50	15.42	10.95	1.57	11/16-24UNEF
14	28.98	23.01	3.05	22.22	20.68	18.59	10.95	1.57	13/16-20UNEF
16	31.34	24.61	3.05	25.40	23.85	21.77	10.95	1.57	15/16-20UNEF
18	33.73	26.97	3.05	28.58	26.39	24.43	10.95	1.57	1 1/16-18UNEF
20	36.91	29.36	3.05	31.75	29.57	27.61	14.12	2.39	1 3/16-18UNEF
22	40.08	31.75	3.05	34.92	32.74	30.78	14.12	2.39	1 5/16-18UNEF
24	43.18	34.93	3.73	38.10	35.92	33.96	14.96	2.39	1 7/16-18UNEF

## Termination Assembly

3110 Class A, E, F, J & P

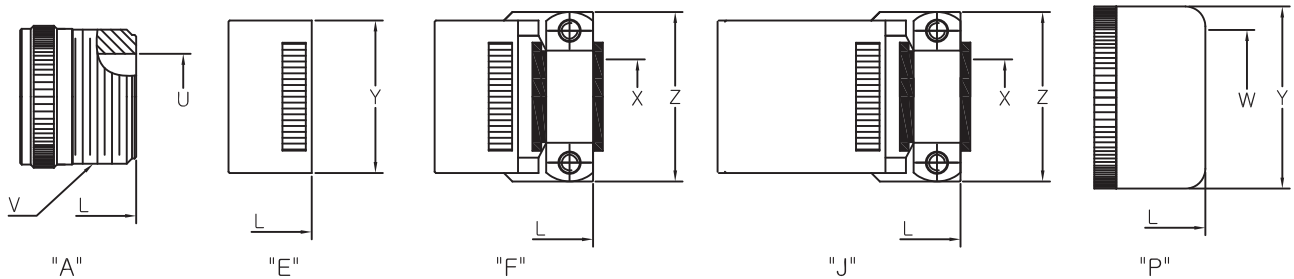

Class	E, F, J, P			A			E	F	J	P	
	X ±0.25	Y max	Z max	L max	U min	V THD-2A	L max	L max	L max	L max	W min
8	3.18	15.44	21.03	36.11	7.54	1/2-28 UNEF	33.73	48.82	57.68	36.91	8.05
10	4.78	18.64	22.63	36.11	10.69	5/8-24 UNEF	33.73	48.82	57.68	36.91	11.02
12	7.92	21.79	25.81	36.11	13.87	3/4-20 UNEF	33.73	48.82	61.24	36.91	13.92
14	9.53	24.99	28.98	36.11	16.84	7/8-20 UNEF	33.73	48.82	66.01	36.91	17.09
16	12.70	28.19	30.56	36.11	19.99	1 -20 UNEF	33.73	51.99	74.75	36.91	20.27
18	15.88	31.34	37.31	36.11	22.33	1 3/16-18 UNEF	33.73	52.78	80.57	36.91	22.83
20	15.88	34.54	37.31	43.26	25.76	1 3/16-18 UNEF	38.89	59.54	91.69	42.47	26.01
22	19.05	37.69	42.06	44.83	28.83	1 7/16-18 UNEF	38.89	59.54	95.66	42.47	29.18
24	20.32	40.89	44.45	44.83	31.98	1 7/16-18 UNEF	40.49	61.11	101.22	44.04	32.36

# MIL-DTL-26482 Series I

## Connector Dimensions

KD3111 Class A, E, F, J & P  
MS3111 Class A, E, F, J & P  
Cable Connecting Plug

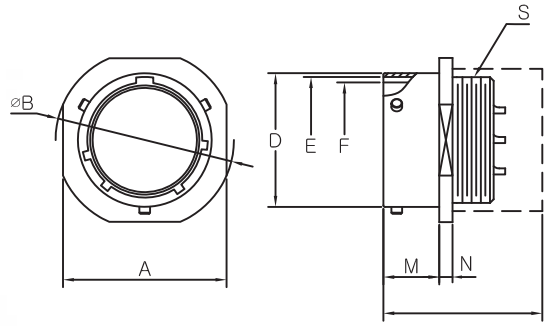

Termination Assembly

Shell size	□A max	∅B ±0.51	∅D +0.03 -0.13	∅E +0.13 -0.15	∅F +0.13 -0.03	M +0.79	N ±0.41	S THD-2A
8	21.03	23.83	12.01	10.46	9.19	10.16	2.39	7/16-28UNEF
10	24.23	26.97	14.99	13.72	12.45	10.16	2.39	9/16-24UNEF
12	26.59	29.36	19.05	17.50	15.42	10.16	2.39	11/16-24UNEF
14	28.98	31.75	22.22	20.68	18.59	10.16	2.39	13/16-20UNEF
16	31.34	34.14	25.40	23.85	21.77	10.16	2.39	15/16-20UNEF
18	33.73	36.53	28.58	26.39	24.43	10.16	2.39	1 1/16-18UNEF
20	36.91	39.67	31.75	29.57	27.61	13.59	2.92	1 3/16-18UNEF
22	40.08	42.88	34.92	32.74	30.78	13.59	2.92	1 5/16-18UNEF
24	43.18	46.02	38.10	35.92	33.96	14.17	2.92	1 7/16-18UNEF

## Termination Assembly

3111 Class A, E, F, J & P

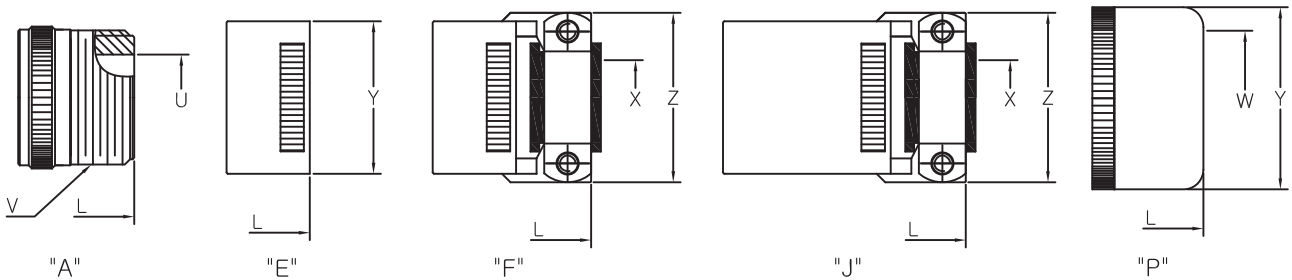

Class	E, F, J, P			A			E	F	J	P	
	X ±0.25	Y max	Z max	L max	U min	V THD-2A	L max	L max	L max	L max	W min
8	3.18	15.44	21.03	36.11	7.54	1/2-28 UNEF	33.73	48.82	57.68	36.91	8.05
10	4.78	18.64	22.63	36.11	10.69	5/8-24 UNEF	33.73	48.82	57.68	36.91	11.02
12	7.92	21.79	25.81	36.11	13.87	3/4-20 UNEF	33.73	48.82	61.24	36.91	13.92
14	9.53	24.99	28.98	36.11	16.84	7/8-20 UNEF	33.73	48.82	66.01	36.91	17.09
16	12.70	28.19	30.56	36.11	19.99	1 -20 UNEF	33.73	51.99	74.75	36.91	20.27
18	15.88	31.34	37.31	36.11	22.33	1 3/16-18 UNEF	33.73	52.78	80.57	36.91	22.83
20	15.88	34.54	37.31	43.26	25.76	1 3/16-18 UNEF	38.89	59.54	91.69	42.47	26.01
22	19.05	37.69	42.06	44.83	28.83	1 7/16-18 UNEF	38.89	59.54	95.66	42.47	29.18
24	20.32	40.89	44.45	44.83	31.98	1 7/16-18 UNEF	40.49	61.11	101.22	44.04	32.36

# MIL-DTL-26482 Series I

## Connector Dimensions

KD3114 Class E, F  
MS3114 Class E, F  
Jam Nut Receptacle

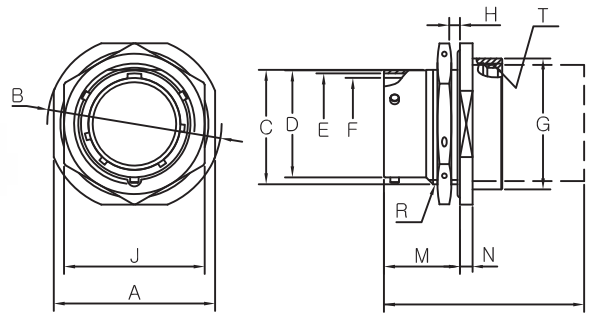

Termination Assembly

Shell size	□A	∅B	C	∅D	∅E	∅F	∅G	H		J	M	N	R	T
	max	-0.81	-0.25	+0.03 -0.13	+0.13 -0.15	+0.13 -0.03	max	min	max	±0.43	+0.79	±0.51	THD-2A	THD-2B
8	24.23	27.38	13.46	12.01	10.46	9.19	19.05	1.57	3.18	19.05	17.55	2.97	9/16-24UNEF	5/8-24UNEF
10	27.38	30.56	16.64	14.99	13.72	12.45	22.23	1.57	3.18	22.23	17.55	2.97	11/16-24UNEF	3/4-20UNEF
12	32.16	35.33	20.78	19.05	17.50	15.42	25.40	1.57	3.18	26.97	17.55	2.97	7/8-20UNEF	7/8-20UNEF
14	35.33	38.51	23.93	22.22	20.68	18.59	28.58	1.57	3.18	30.18	17.55	2.97	1 -20UNEF	1 -20UNEF
16	38.51	41.68	27.08	25.40	23.85	21.77	31.75	1.57	3.18	33.32	17.55	2.97	1 1/8-18UNEF	1 1/8-18UNEF
18	41.68	44.86	30.25	28.58	26.39	24.43	34.93	1.57	3.18	36.53	17.55	2.97	1 1/4-18UNEF	1 1/4-18UNEF
20	46.43	49.63	33.43	31.75	29.57	27.61	38.89	1.57	6.35	39.67	22.33	3.76	1 3/8-18UNEF	1 3/8-18UNEF
22	49.63	52.78	36.60	34.92	32.74	30.78	42.06	1.57	6.35	42.88	22.33	3.76	1 1/2-18UNEF	1 1/2-18UNEF
24	52.78	55.96	39.78	38.10	35.92	33.96	45.24	1.57	6.35	46.02	23.16	3.76	1 5/8-18UNEF	1 5/8-18UNEF

## Termination Assembly

3114 Class A, E, F & P

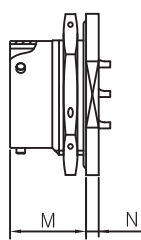

"A"

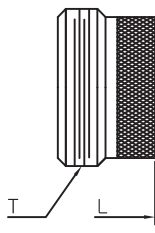

"E"

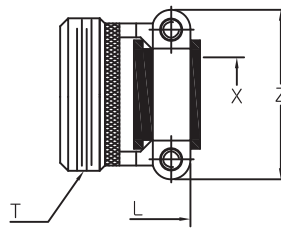

"F"

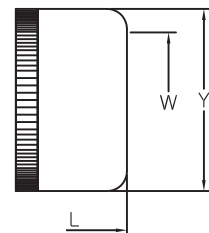

"P"

Class	A		F, P			E, F	E	F	P	
	M	N	X	Y	Z	T	L	L	L	W
Shell size	+0.79	±0.51	±0.25	max	max	THD-2B	max	max	max	min
8	17.55	2.97	3.18	15.44	21.03	5/8-24UNEF	34.14	48.41	35.33	8.05
10	17.55	2.97	4.78	18.64	22.63	3/4-20UNEF	34.14	48.41	35.33	11.02
12	17.55	2.97	7.92	21.79	25.81	7/8-20UNEF	34.14	48.41	35.33	13.92
14	17.55	2.97	9.53	24.99	28.98	1 -20UNEF	34.14	48.41	35.33	17.09
16	17.55	2.97	12.70	28.19	30.56	1 1/8-18UNEF	34.14	51.99	35.33	20.27
18	17.55	2.97	15.88	31.34	37.31	1 1/4-18UNEF	34.14	52.78	35.33	22.83
20	22.33	3.76	15.88	34.54	37.31	1 3/8-18UNEF	40.49	59.13	41.68	26.01
22	22.33	3.76	19.05	37.69	42.06	1 1/2-18UNEF	40.49	59.13	41.68	29.18
24	23.16	3.76	20.32	40.89	44.45	1 5/8-18UNEF	41.68	62.31	43.26	32.36

# MIL-DTL-26482 Series I

## Connector Dimensions

KD3116 Class A, E, F, J & P  
MS3116 Class A, E, F, J & P  
Straight Plug

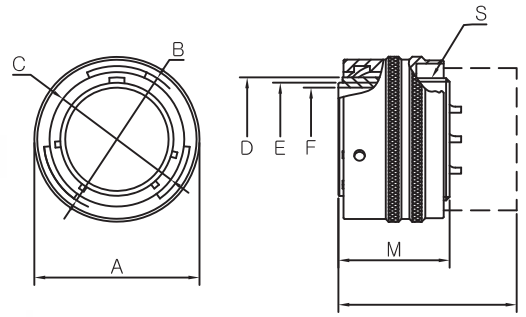

Termination Assembly

Shell size	øA max	øB +0.13 -0.15	øC +0.13 -0.03	øD +0.13 -0.15	øE +0.03 -0.13	øF min	M ±0.13	S THD-2A
8	19.86	14.63	12.22	10.11	9.07	7.42	21.10	7/16-28UNEF
10	23.52	17.70	15.29	13.36	12.32	10.39	21.10	9/16-24UNEF
12	26.49	22.12	19.33	17.14	15.17	13.28	21.10	11/16-24UNEF
14	30.05	25.27	22.48	20.32	18.34	16.46	21.10	13/16-20UNEF
16	33.15	28.45	25.65	23.49	21.52	19.61	21.10	15/16-20UNEF
18	35.33	31.62	28.85	26.03	24.06	21.89	21.10	1 1/16-18UNEF
20	38.89	34.80	32.00	29.21	27.23	25.07	24.90	1 3/16-18UNEF
22	42.06	37.97	35.18	32.38	30.41	28.22	24.90	1 5/16-18UNEF
24	45.13	41.25	38.35	35.56	33.58	31.42	26.40	1 7/16-18UNEF

## Termination Assembly

3116 Class A, E, F, J & P

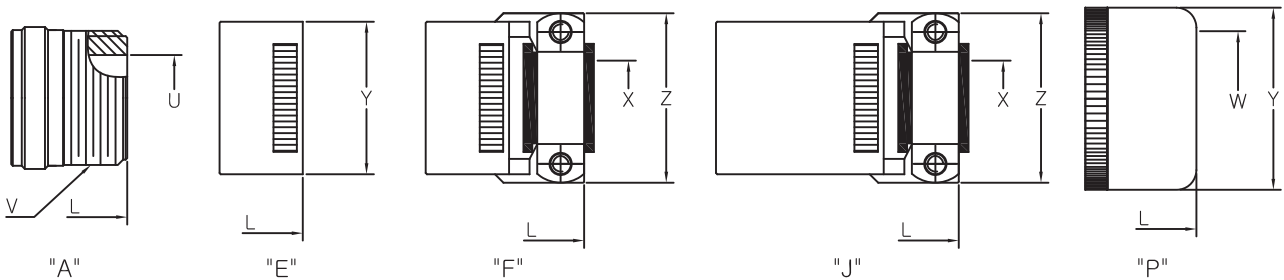

Class	E, F, J, P			A			E	F	J	P	
	X ±0.25	Y max	Z max	L max	U min	V THD-2A	L min	L max	L max	L max	W min
8	3.18	15.44	21.03	36.68	7.54	1/2-28 UNEF	33.73	48.41	57.68	38.10	8.05
10	4.78	18.64	22.63	36.68	10.69	5/8-24 UNEF	33.73	48.41	57.68	38.10	11.02
12	7.92	21.79	25.81	36.68	13.87	3/4-20 UNEF	33.73	48.41	61.24	38.10	13.92
14	9.53	24.99	28.98	36.68	16.84	7/8-20 UNEF	33.73	48.41	66.01	38.10	17.09
16	12.70	28.19	30.56	36.68	19.99	1 -20 UNEF	33.73	51.99	74.75	38.10	20.27
18	15.88	31.34	37.31	36.68	22.33	1 3/16-18 UNEF	33.73	55.32	80.57	38.10	22.83
20	15.88	34.54	37.31	43.89	25.76	1 3/16-18 UNEF	36.91	57.15	91.69	40.87	26.01
22	19.05	37.69	42.06	43.89	28.83	1 7/16-18 UNEF	36.91	57.15	95.66	40.87	29.18
24	20.32	40.89	44.45	44.15	31.98	1 7/16-18 UNEF	38.35	58.72	101.22	42.85	32.36

# MIL-DTL-26482 Series I

## Connector Dimensions

KD3112 Class E  
MS3112 Class E  
Box Mounting Receptacle

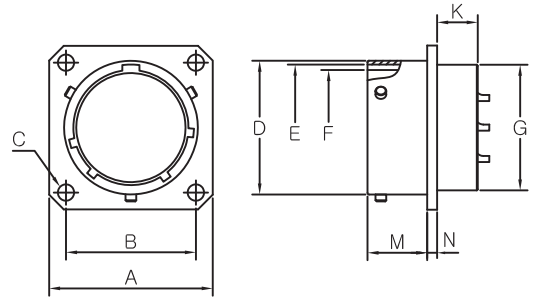

Shell size	□A	□B	∅C	∅D	∅E	∅F	∅G	K	M	N
	max	±0.13	±0.13	+0.03 -0.13	+0.13 -0.15	+0.13 -0.03	+0.79 -0.41	max	+0.79	±0.41
8	21.03	15.09	3.05	12.01	10.46	9.19	11.12	8.99	10.95	1.57
10	24.23	18.26	3.05	14.99	13.72	12.45	14.27	8.99	10.95	1.57
12	26.59	20.62	3.05	19.05	17.50	15.42	17.48	8.99	10.95	1.57
14	28.98	23.01	3.05	22.22	20.68	18.59	20.62	8.99	10.95	1.57
16	31.34	24.61	3.05	25.40	23.85	21.77	23.83	8.99	10.95	1.57
18	33.73	26.97	3.05	28.58	26.39	24.43	26.97	8.99	10.95	1.57
20	36.91	29.36	3.05	31.75	29.57	27.61	30.18	10.59	14.12	2.39
22	40.08	31.75	3.05	34.92	32.74	30.78	33.32	10.59	14.12	2.39
24	43.26	34.93	3.73	38.10	35.92	33.96	36.53	11.30	14.96	2.39

## Connector Dimensions

KD3112 Class EP  
Box Mounting Receptacle  
of rear panel mounting

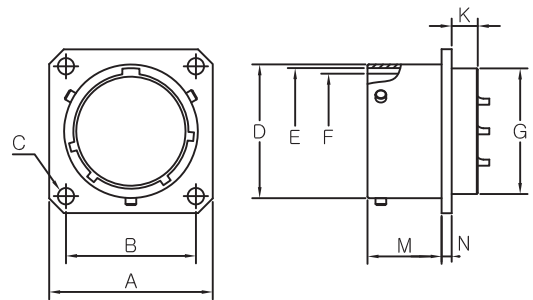

Shell size	□A	□B	∅C	∅D	∅E	∅F	∅G	K	M	N
	max	±0.13	±0.13	+0.03 -0.13	+0.13 -0.15	+0.13 -0.03	+0.79 -0.41	max	+0.79	±0.41
8	21.03	15.09	3.05	12.01	10.46	9.19	11.12	6.45	13.49	1.57
10	24.23	18.26	3.05	14.99	13.72	12.45	14.27	6.45	13.49	1.57
12	26.59	20.62	3.05	19.05	17.50	15.42	17.48	6.45	13.49	1.57
14	28.98	23.01	3.05	22.22	20.68	18.59	20.62	6.45	13.49	1.57
16	31.34	24.61	3.05	25.40	23.85	21.77	23.83	6.45	13.49	1.57
18	33.73	26.97	3.05	28.58	26.39	24.43	26.97	6.45	13.49	1.57
20	36.91	29.36	3.05	31.75	29.57	27.61	30.18	8.05	16.66	2.39
22	40.08	31.75	3.05	34.92	32.74	30.78	33.32	8.05	16.66	2.39
24	43.26	34.93	3.73	38.10	35.92	33.96	36.53	9.60	16.66	2.39



# MIL-DTL-26482 Series I

## Connector Dimensions

KD3112 Class PC  
Box Mounting Receptacle  
With PCB Contacts

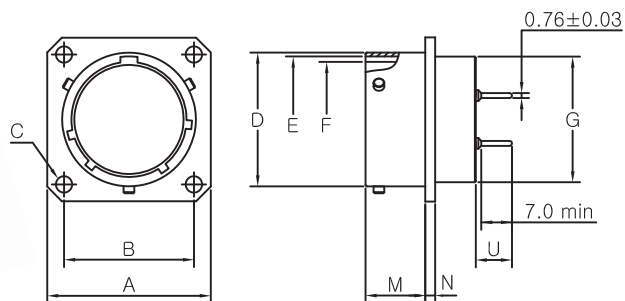

Shell size	□A max	□B ±0.13	∅C ±0.13	∅D +0.03 -0.13	∅E +0.13 -0.15	∅F +0.13 -0.03	∅G +0.79 -0.41	M +0.79	N ±0.41	U ±0.5
8	21.03	15.09	3.05	12.01	10.46	9.19	11.12	10.95	1.57	9.5
10	24.23	18.26	3.05	14.99	13.72	12.45	14.27	10.95	1.57	9.5
12	26.59	20.62	3.05	19.05	17.50	15.42	17.48	10.95	1.57	9.5
14	28.98	23.01	3.05	22.22	20.68	18.59	20.62	10.95	1.57	9.5
16	31.34	24.61	3.05	25.40	23.85	21.77	23.83	10.95	1.57	9.5
18	33.73	26.97	3.05	28.58	26.39	24.43	26.97	10.95	1.57	9.5
20	36.91	29.36	3.05	31.75	29.57	27.61	30.18	14.12	2.39	8.5
22	40.08	31.75	3.05	34.92	32.74	30.78	33.32	14.12	2.39	8.5
24	43.26	34.93	3.73	38.10	35.92	33.96	36.53	14.96	2.39	8.0

## Connector Dimensions

KD3114 PC  
Jam Nut Receptacle  
With PCB Contacts

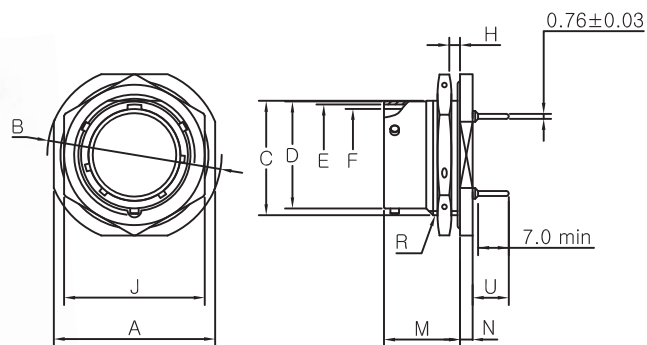

Shell size	□A max	∅B -0.81	C -0.25	∅D +0.03 -0.13	∅E +0.13 -0.15	∅F +0.13 -0.03	H		J ±0.43	M +0.79	N ±0.51	R THD-2A	U ±0.5
							min	max					
8	24.23	27.38	13.46	12.01	10.46	9.19	1.57	3.18	19.05	17.55	2.97	9/16-24UNEF	9.5
10	27.38	30.56	16.64	14.99	13.72	12.45	1.57	3.18	22.23	17.55	2.97	11/16-24UNEF	9.5
12	32.16	35.33	20.78	19.05	17.50	15.42	1.57	3.18	26.97	17.55	2.97	7/8-20UNEF	9.5
14	35.33	38.51	23.93	22.22	20.68	18.59	1.57	3.18	30.18	17.55	2.97	1 -20UNEF	9.5
16	38.51	41.68	27.08	25.40	23.85	21.77	1.57	3.18	33.32	17.55	2.97	1 1/8-18UNEF	9.5
18	41.68	44.86	30.25	28.58	26.39	24.43	1.57	3.18	36.53	17.55	2.97	1 1/4-18UNEF	9.5
20	46.43	49.63	33.43	31.75	29.57	27.61	1.57	6.35	39.67	22.33	3.76	1 3/8-18UNEF	8.5
22	49.63	52.78	36.60	34.92	32.74	30.78	1.57	6.35	42.88	22.33	3.76	1 1/2-18UNEF	8.5
24	52.78	55.96	39.78	38.10	35.92	33.96	1.57	6.35	46.02	23.16	3.76	1 5/8-18UNEF	8.0

# MIL-DTL-26482 Series I

## Connector Dimensions

KD3115  
MS3115  
Dummy Stowage Receptacle

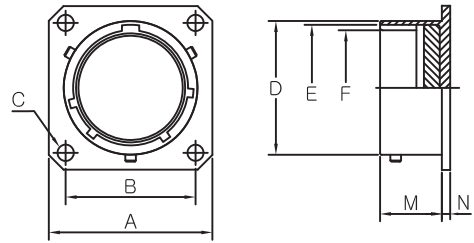

Shell size	□A max	□B ±0.13	∅C ±0.13	∅D +0.03 -0.13	∅E +0.13 -0.15	∅F +0.13 -0.03	M +0.79	N ±0.41
8	21.03	15.09	3.05	12.01	10.46	9.19	11.73	1.57
10	24.23	18.26	3.05	14.99	13.72	12.45	11.73	1.57
12	26.59	20.62	3.05	19.05	17.50	15.42	11.73	1.57
14	28.98	23.01	3.05	22.22	20.68	18.59	11.73	1.57
16	31.34	24.61	3.05	25.40	23.85	21.77	11.73	1.57
18	33.73	26.97	3.05	28.58	26.39	24.43	11.73	1.57
20	36.91	29.36	3.05	31.75	29.57	27.61	14.12	2.39
22	40.08	31.75	3.05	34.92	32.74	30.78	14.12	2.39
24	43.26	34.93	3.73	38.10	35.92	33.96	14.96	2.39

## Connector Dimensions

KD3119 Class E  
MS3119 Class E  
Thru-Bulkhead Receptacle

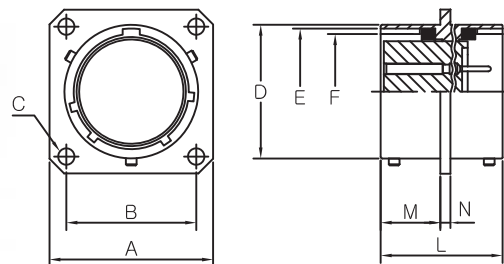

Shell size	□A max	□B ±0.13	∅C ±0.13	∅D +0.03 -0.13	∅E +0.13 -0.15	∅F +0.13 -0.03	L max	M +0.79	N ±0.41
8	21.03	15.09	3.05	12.01	10.46	9.19	28.58	13.49	1.57
10	24.23	18.26	3.05	14.99	13.72	12.45	28.58	13.49	1.57
12	26.59	20.62	3.05	19.05	17.50	15.42	28.58	13.49	1.57
14	28.98	23.01	3.05	22.22	20.68	18.59	28.58	13.49	1.57
16	31.34	24.61	3.05	25.40	23.85	21.77	28.58	13.49	1.57
18	33.73	26.97	3.05	28.58	26.39	24.43	28.58	13.49	1.57
20	36.91	29.36	3.05	31.75	29.57	27.61	35.71	16.66	2.39
22	40.08	31.75	3.05	34.92	32.74	30.78	35.71	16.66	2.39
24	43.26	34.93	3.73	38.10	35.92	33.96	35.71	16.66	2.39

# MIL-DTL-26482 Series I

## Accessories

KD3180  
MS3180  
Cover Protecting caps for Plugs

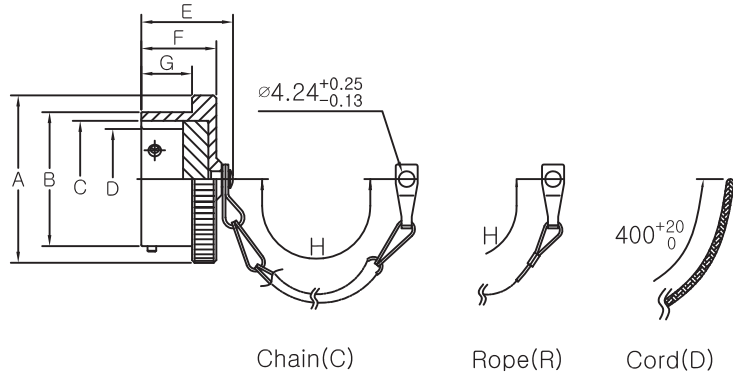

KD order No.			Shell size	$\varnothing A$ max	$\varnothing B$ $+0.03$ $-0.13$	$\varnothing C$ $+0.13$ $-0.15$	$\varnothing D$ $+0.13$ $-0.03$	E max	F max	G $+0.25$	H $+12.70$ $- 6.35$
Chain	Rope	Nylon Cord									
KD3180-8C	-8R	-8D	8	18.26	12.01	10.46	9.19	19.84	14.27	9.35	76.20
KD3180-10C	-10R	-10D	10	21.44	14.99	13.72	12.45	19.84	14.27	9.35	76.20
KD3180-12C	-12R	-12D	12	25.40	19.05	17.50	15.42	19.84	14.27	9.35	88.90
KD3180-14C	-14R	-14D	14	28.58	22.22	20.68	18.59	19.84	14.27	9.35	88.90
KD3180-16C	-16R	-16D	16	31.75	25.40	23.85	21.77	19.84	14.27	9.35	88.90
KD3180-18C	-18R	-18D	18	34.92	28.58	26.39	24.43	19.84	14.27	9.35	88.90
KD3180-20C	-20R	-20D	20	38.10	31.75	29.57	27.61	21.44	15.88	10.92	101.60
KD3180-22C	-22R	-22D	22	41.28	34.92	32.74	30.78	21.44	15.88	10.92	101.60
KD3180-24C	-24R	-24D	24	44.45	38.10	35.92	33.96	22.22	16.71	11.76	101.60

KD3181  
MS3181  
Cover Protecting caps for Receptacles

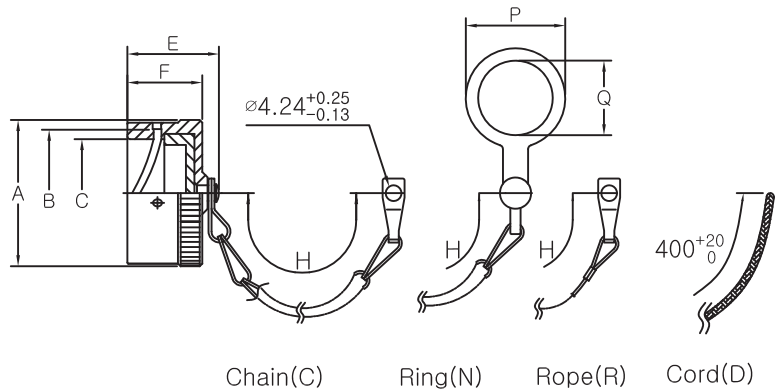

KD order No.				Shell size	$\varnothing A$ max	$\varnothing B$ $+0.13$ $-0.15$	$\varnothing C$ $+0.13$ $-0.03$	E max	F max	H $+12.70$ $- 6.35$	$\varnothing P$ max	$\varnothing Q$ min
Chain	Rope	Ring	Nylon Cord									
KD3181-8C	-8R	-8N	-8D	8	18.64	14.63	12.22	21.44	14.27	76.20	20.62	14.68
KD3181-10C	-10R	-10N	-10D	10	21.82	17.70	15.29	21.44	14.27	76.20	25.40	17.86
KD3181-12C	-12R	-12N	-12D	12	25.40	22.12	19.33	21.44	14.27	88.90	30.18	22.63
KD3181-14C	-14R	-14N	-14D	14	28.58	25.27	22.48	21.44	14.27	88.90	36.53	25.81
KD3181-16C	-16R	-16N	-16D	16	31.75	28.45	25.65	21.44	14.27	88.90	39.67	28.98
KD3181-18C	-18R	-18N	-18D	18	34.92	31.62	28.85	21.44	14.27	88.90	42.88	32.16
KD3181-20C	-20R	-20N	-20D	20	38.10	34.80	32.00	21.44	14.27	101.60	46.02	35.33
KD3181-22C	-22R	-22N	-22D	22	41.28	37.97	35.18	21.44	14.27	101.60	49.23	38.51
KD3181-24C	-24R	-24N	-24D	24	44.45	41.25	38.35	22.22	15.29	101.60	52.37	41.68

# MIL-DTL-26482 Series I

## Cross Reference Lists

KD	MILITARY	AMPHENOL / BENDIX	S.E.C / ARRAY	FCI / BURNDY	FCI / SOURIAU	ITT CANNON	SPACECRAFT	VEAM	WPI / GENERAL
KD3110A	MS3110A	PT00A	PW00A	BT00A	851-00A*50	KPT00A	SCPT3100A	VPT00A	-
KD3110E	MS3110E	PT00E	PW00E	BT00E	851-00E*50	KPT00E	SCPT3100E	VPT00E	GC00E
KD3110F	MS3110F	PT00F(SR)	PW00F	BT00EC	851-00EC*50	KPT00F	SCPT3100F	VPT00E(SR)	GC00F
KD3110J	MS3110J	-	PW00JF	BT00JF	851-00JC*50	KPT00J	SCPT3100J	VPT00W	-
KD3110P	MS3110P	PT00P	PW00P	BT00P	851-00P*50	KPT00P	SCPT3100P	VPT00P	GC00P
KD3111A	MS3111A	PT01A	PW01A	BT01A	851-01A*50	KPT01A	SCPT3111A	VPT01A	-
KD3111E	MS3111E	PT01E	PW01E	BT01E	851-01E*50	KPT01E	SCPT3111E	VPT01E	GC01E
KD3111F	MS3111F	PT01E(SR)	PW01F	BT01EC	851-01EC*50	KPT01F	SCPT3111F	VPT01E(SR)	GC01F
KD3111J	MS3111J	-	PW01JF	BT01JF	851-01JC*50	KPT01J	SCPT3111J	VPT01W	GC01J
KD3111P	MS3111P	PT01P	PW01P	BT01P	851-01P*50	KPT01P	SCPT3111P	VPT01P	GC01P
KD3112A	MS3112A	PT02A	PW02A	BT02A	851-02A*50	KPT02A	SCPT3112A	VPT02A	-
KD3112E	MS3112E	PT02E	PW02E	BT02E	851-02E*50	KPT02E	SCPT3112E	VPT02E	GC02E
KD3112EP	-	-	-	-	-	-	-	-	-
KD3112PC	-	-	-	-	-	-	-	-	-
KD3114A	-	-	-	-	851-07A*50	-	-	-	-
KD3114E	MS3114E	PT07E	PW07E	BT07E	851-07E*50	KPT07E	SCPT3114E	VPT07E	GC07E
KD3114F	MS3114F	PT07E(SR)	PW07F	BT07EC	851-07EC*50	KPT07F	SCPT3114F	VPT07E(SR)	-
KD3114P	MS3114P	PT07P	PW07P	BT07P	851-07P*50	KPT07P	SCPT3114P	VPT07P	-
KD3114PC	-	-	-	-	-	-	-	-	-
KD3116A	MS3116A	PT06A	PW06A	BT06A	851-06A*50	KPT06A	SCPT3116A	VPT06A	-
KD3116E	MS3116E	PT06E	PW06E	BT06E	851-06E*50	KPT06E	SCPT3116E	VPT06E	GC06E
KD3116F	MS3116F	PT06E(SR)	PW06F	BT06EC	851-06EC*50	KPT06F	SCPT3116F	VPT06E(SR)	GC06F
KD3116J	MS3116J	-	PW06J	BT06JF	851-06JC*50	KPT06J	SCPT3116J	VPT06W	GC06J
KD3116P	MS3116P	PT06P	PW06P	BT06P	851-06P*50	KPT06P	SCPT3116P	VPT06P	GC06P
KD3119E	MS3119E	PTB	-	-	-	KPTB	-	VPTB	-